

OPTION

Shuttle

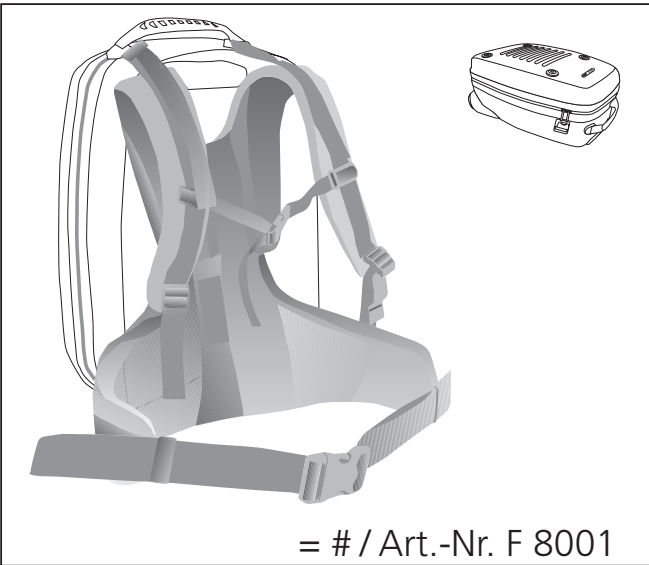

= # / Art.-Nr. F 8001

OPTION

Office-Bag2

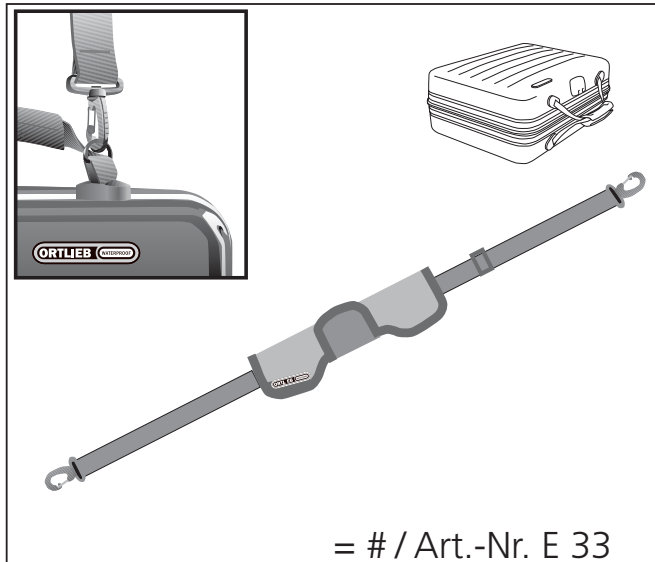

= # / Art.-Nr. E 33

OPTION

Shuttle

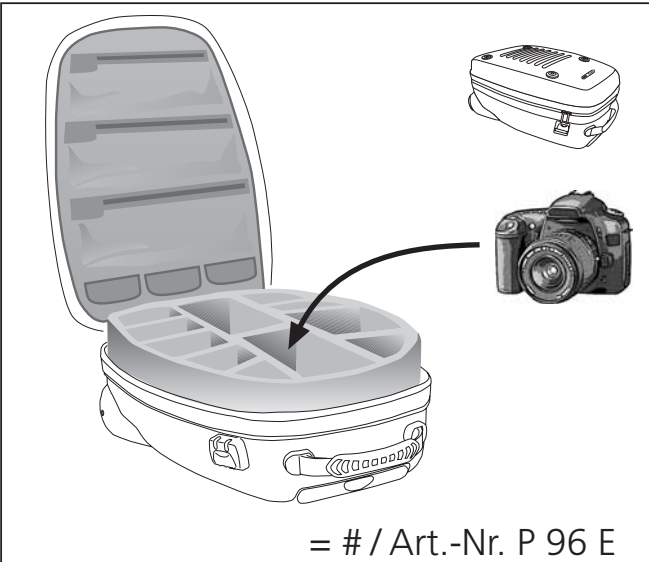

= # / Art.-Nr. P 96 E

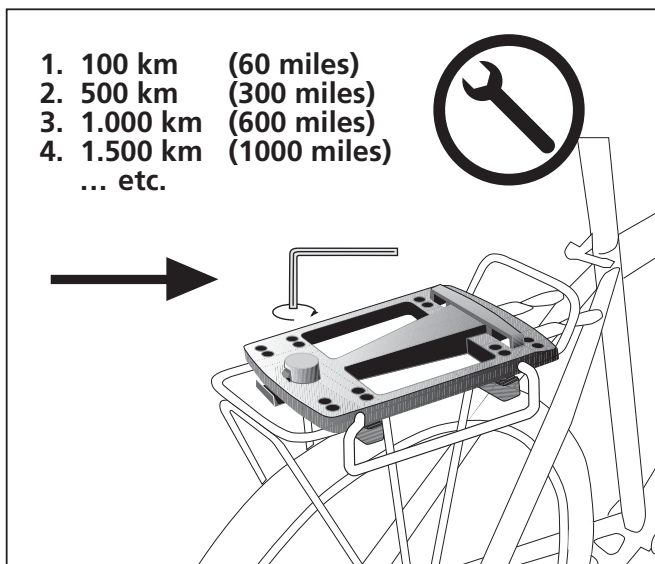

1. 100 km (60 miles)
2. 500 km (300 miles)
3. 1.000 km (600 miles)
4. 1.500 km (1000 miles)
- ... etc.



ACCESSOIRES / ACCESSORIES

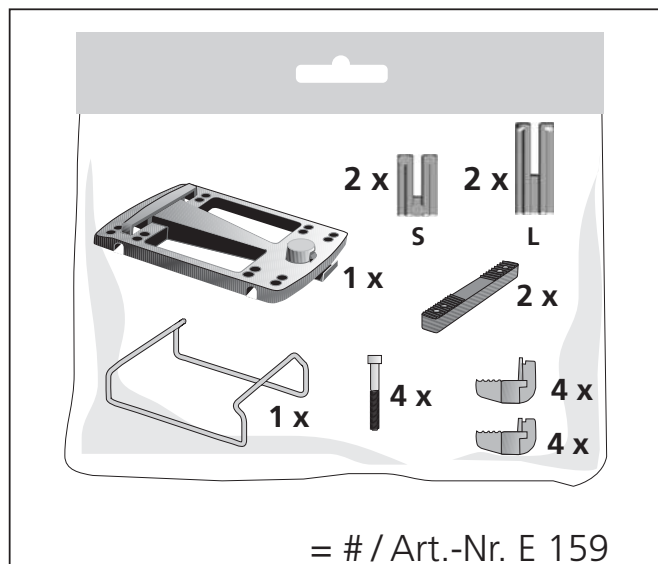

= # / Art.-Nr. E 159

WY206 0308

- (D) MONTAGEANWEISUNG:
- (GB) ASSEMBLY INSTRUCTIONS:
- (F) INSTRUCTIONS DE MONTAGE:
- (I) ISTRUZIONI DI MONTAGGIO:
- (NL) MONTAGE HANDLEIDING:
- (DK) MONTERINGSVEJLEDNING:
- (E) INSTRUCCIONES DE MONTAJE:
- (S) MONTERINGSANVISNING:
- (N) MONTERINGSANVISNING:
- (SF) ASENNUSOHJEET:
- (PL) INSTRUKCJA MONTAZU:
- (J) 組立方法



